

Designed and manufactured in South Africa

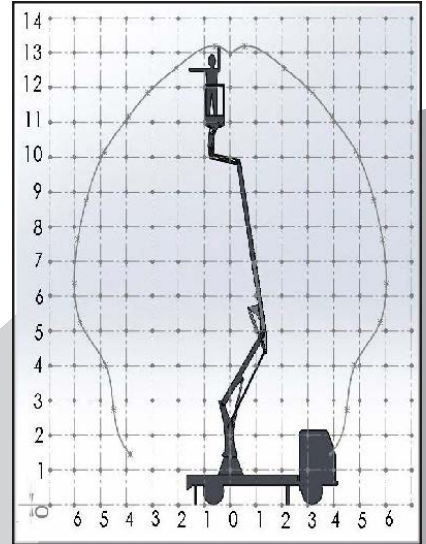
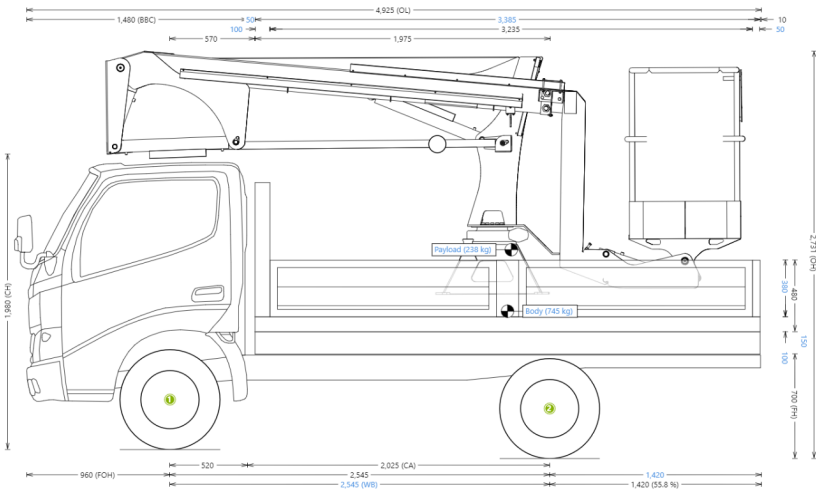

WORKING FLIGHT ENVELOPE

- ▶ Working Height: 13m
- ▶ Max horizontal reach: 6m
- ▶ Basket: 2man
- ▶ Tare mass 930kg
- ▶ Power System: PTO
- ▶ Basket size: 750 x 1200
- ▶ Safe working load: 250kg
- ▶ Controls: Hydraulic top & bottom
- ▶ 4x hydraulic stabilizers with leg lock valve
- ▶ 360 degree non-continuous rotation
- ▶ Hydraulic operated control valve from both the ground and the cage
- ▶ Manual override in the event of system failure
- ▶ Polyethylene 2 man work basket 1000kv
- ▶ Emergency pump

1306 with Jib

## Key Features

- Integrated base and outrigger system
- Simple, ergonomic design for Utility vehicles
- Individual stabilizer control valve
- Articulated telescopic configuration
- No plastic mouldings
- Manufactured according to SANS Standards
- Multiple options on baskets
- Additional accessories available on request
- Custom utility body with sub frame and lights (Optional)

Robust design with interlocking outriggers, Dead Man controls, overload interlocking and in complete compliance with the South African National Standards 16368.